

SMD(Surface-Mount Device) Resettable Fuse: DM-PSMD Series

**Features:**

- ✧ RoHS Compliant & Halogen Free
- ✧ faster tripping, 0805 Dimension, Surface mountable, Solid state
- ✧ Operation Current: 0.05A~1.10A
- ✧ Maximum Voltage: 6V~15Vdc
- ✧ Operating Temperature: -40°C TO 85°C

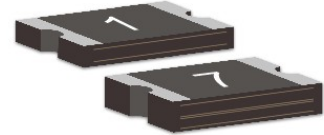

**Product Dimensions**

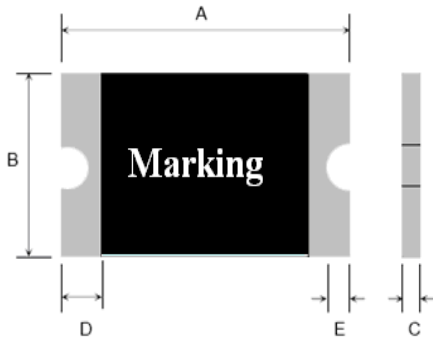

Material of terminal pad: Tin-Plated Nickle-copper  
 Solderability of terminal pad: Meets EIA specification  
 RS 186-9E and ANSI/J-STD-002 Category 3.

Pig.1

Unit : mm

Model	Marking	A		B		C		D	E
		Min	Max	Min	Max	Min	Max	Min	Min
DM-PSMD-005	1	2.00	2.20	1.20	1.50	0.45	1.00	0.20	0.10
DM-PSMD-010	1	2.00	2.20	1.20	1.50	0.40	1.00	0.20	0.10
DM-PSMD-020	2	2.00	2.20	1.20	1.50	0.40	1.00	0.20	0.10
DM-PSMD-035	3	2.00	2.20	1.20	1.50	0.30	1.00	0.20	0.10
DM-PSMD-050	5	2.00	2.20	1.20	1.50	0.40	0.80	0.20	0.10
DM-PSMD-075	7	2.00	2.20	1.20	1.50	0.50	1.20	0.20	0.10
DM-PSMD-100	0	2.00	2.20	1.20	1.50	0.50	1.20	0.20	0.10
DM-PSMD-110	0	2.00	2.20	1.20	1.50	0.50	1.20	0.20	0.10

Thermal Derating Chart-I<sub>H</sub> (A)

Model	Maximum ambient operating temperatures (°C)								
	-40	-20	0	25	40	50	60	70	85
DM-PSMD-005	0.07	0.06	0.055	0.05	0.04	0.35	0.3	0.25	0.15
DM-PSMD-010	0.14	0.12	0.11	0.1	0.8	0.7	0.6	0.5	0.3
DM-PSMD-020	0.28	0.25	0.23	0.20	0.17	0.14	0.12	0.10	0.07
DM-PSMD-035	0.47	0.44	0.39	0.35	0.30	0.27	0.24	0.20	0.14
DM-PSMD-050	0.68	0.62	0.55	0.50	0.40	0.37	0.33	0.29	0.23
DM-PSMD-075	1.00	0.90	0.79	0.75	0.63	0.57	0.53	0.41	0.34
DM-PSMD-100	1.35	1.25	1.10	1.00	0.82	0.74	0.65	0.55	0.42
DM-PSMD-110	1.45	1.35	1.20	1.10	0.92	0.84	0.75	0.65	0.52

### Electrical Characteristics

Model	V <sub>max</sub> (Vdc)	I <sub>max</sub> (A)	I <sub>hold</sub> @25°C (A)	I <sub>trip</sub> @25°C (A)	P <sub>d</sub> (W)	Maximum time to trip		Resistance	
						Current	Time	R <sub>i min</sub>	R <sub>l max</sub>
						(A)	(Sec)	(Ω)	(Ω)
DM-PSMD-005	15	100	0.05	0.15	0.5	0.5	2.00	2.00	50.0
DM-PSMD-010	15	100	0.10	0.30	0.5	0.5	1.50	1.00	6.00
DM-PSMD-020	9	100	0.20	0.50	0.5	8.0	0.02	0.50	3.50
DM-PSMD-035	6	100	0.35	0.75	0.5	8.0	0.10	0.25	1.20
DM-PSMD-050	6	100	0.50	1.00	0.6	8.0	0.10	0.15	0.85
DM-PSMD-075	6	100	0.75	1.50	0.6	8.0	0.20	0.09	0.385
DM-PSMD-100	6	100	1.00	1.95	0.6	8.0	0.30	0.06	0.23
DM-PSMD-110	6	100	1.10	2.20	0.6	8.0	0.30	0.06	0.21

### Part Numbering System

DM-PSMD - □□□ - □

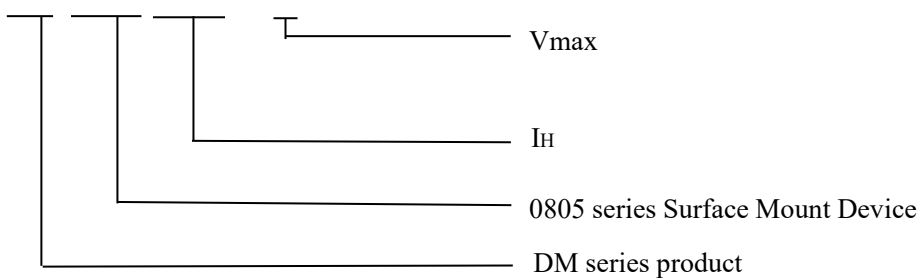

### Test Procedures and Requirements

Test	Test Conditions	Accept/Reject Criteria
------	-----------------	------------------------

Resistance	In still air @ 25°C	$R_{min} \leq R \leq R_{max}$
Time to Trip	Specified current, $V_{max}$ , 25°C	Tmaximum Time to Trip
Hold Current	30min, at $I_H$ , 25°C	No trip
Trip Cycle Life	$V_{max}$ , $I_{max}$ , 100cycles	No arcing or burning
Trip Endurance	$V_{max}$ , 1 hours	No arcing or burning

Physical Characteristics and Environmental Specifications

Physical Characteristics

Terminal materials :	Tin-Plated Nickle-copper
Soldering zone	Meets EIA specification RS 186-9E and ANSI/J-STD-002 Category 3.
Moisture sensitivity	Level 2a, per IPC/JEDEC J-STD 020C

Environmental Specifications

Test	Conditions	Resistance Change
Passive aging	85°C,1000hours	±10% typical
Humidity aging	85°C/85%RH.100 hours	±5% typical
Thermal shock	MIL-STD-202,Method 107G +85°C/-40°C,20times	-30% typical
Solvent Resistance	MIL-STD-202,Method 215	no change
Vibration	ML-STD-883C,Test Condition A	no change

Electrical Specifications:

$I_H$ =Hold current:Maximum current at which the device will not interrupt in 25°C still air.

$I_T$ =Trip current:Minimum current at which the device from low resistance to high resistance in 25°C still air.

$V_{max}$  = Maximum operating voltage device can withstand without damage at rated current.

$I_{max}$  = Maximum fault current device can withstand without damage at rated voltage.

$P_d$ =Maximum power dissipation when device is in the tripped state in 25°C still air environment at rated voltage.

$T_{trip}$ =Maximum time to trip(s) at assigned current.

$R_{i_{min}}$  = Minimum device resistance prior to tripping at 25°C still air..

$R_{l_{max}}$  = Maximum device resistance is measured one hour post reflow.

Recommended pad layout (mm)

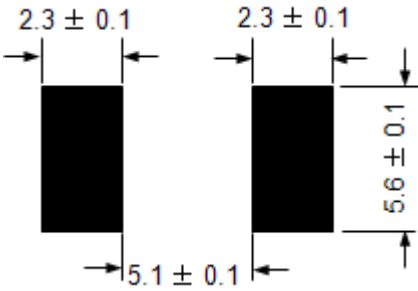

Solder reflow Profiles

Profile Feature	Pb-Free Assembly
Average ramp up rate (T <sub>S</sub> MAX to T <sub>p</sub> )	3°C/second max.
<b>Preheat</b>	
• Temperature min. (T <sub>S</sub> MIN)	150°C
• Temperature max. (T <sub>S</sub> MAX)	200°C
• Time (t <sub>S</sub> MIN to t <sub>S</sub> MAX)	60-120 seconds
<b>Time maintained above:</b>	
• Temperature (T <sub>L</sub> )	217°C
• Time (t <sub>L</sub> )	60-150 seconds
<b>Peak/Classification temperature (T<sub>p</sub>)</b>	260°C
<b>Time within 5°C of actual peak temperature</b>	
Time (t <sub>p</sub> )	30 seconds max.
<b>Ramp down rate</b>	3°C/second max.
<b>Time 25°C to peak temperature</b>	8 minutes max.

Note: All temperatures refer to topside of the package, measured on the package body surface.

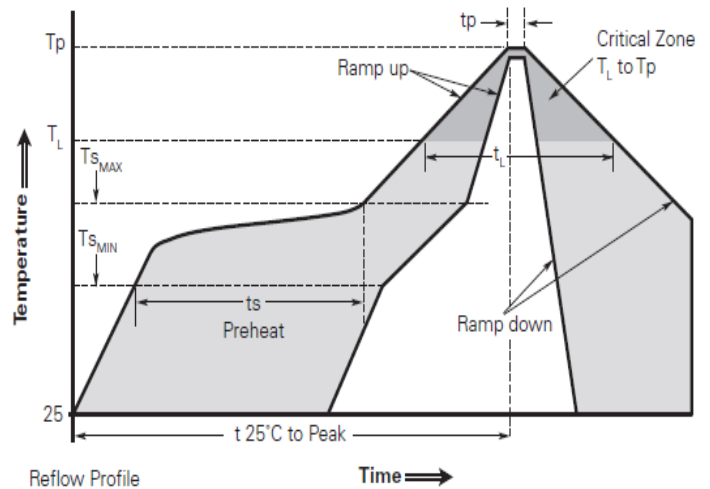

- Recommended reflow methods: IR, vapor phase oven, hot air oven, N2 environment for lead-free.
- Jinrui believes that the optimum conditions for forming acceptable solder fillets occur when a reasonable amount of solder paste is placed underneath each device's via. As such, Jinrui requests that customers comply with our recommended solder pad layouts.
- Recommended maximum paste thickness is 0.25mm (0.010inch).
- Devices can be cleaned using standard industry methods and solvents.
- Jinrui requests that customer board layouts refrain from placing raised features (e.g. vias, nomenclature, traces, etc.) underneath SMD devices. It is possible that raised features could negatively impact solderability performance of our devices.

Notes: If reflow temperatures exceed the recommended profile, devices may not meet the performance requirements.

Rework: SMD series rework should be confined to removal of the installed product and replacement with a fresh device.

Please also avoid direct contact to the device.

Tape Specifications and Reel Dimensions

Coverage specification	
EIA 481-1(Unit: mm)	
W	8.00± 0.30
P <sub>0</sub>	4.0 ± 0.10
P <sub>1</sub>	4.0± 0.10
P <sub>2</sub>	2.0 ± 0.05
A <sub>0</sub>	1.65 ± 0.10
B <sub>0</sub>	2.35 ± 0.10
D <sub>0</sub>	1.55± 0.05
F	3.50± 0.05
E <sub>1</sub>	1.75 ± 0.10
T	0.20± 0.10
Leader min.	390
Trailer min.	160
Reel Dimensions	
A	178±1.0
N	59±1
W <sub>1</sub>	8.5+1.0/-0.2
W <sub>2</sub>	12.0±1

**EIA Tape Component Dimentions**

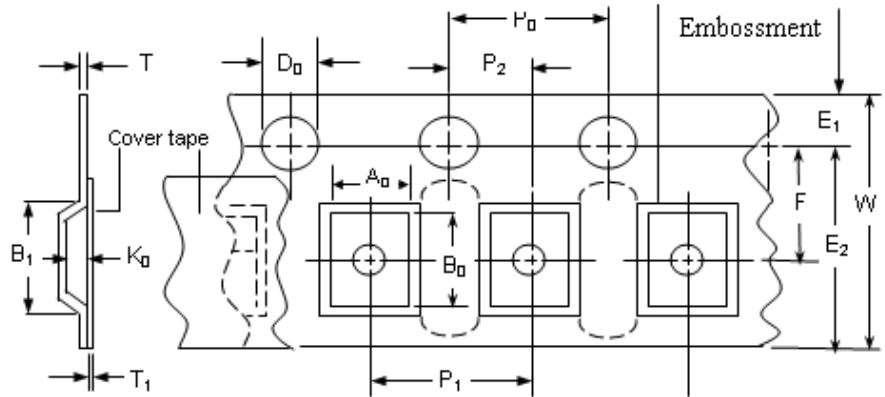

**EIA Reel Dimentions**

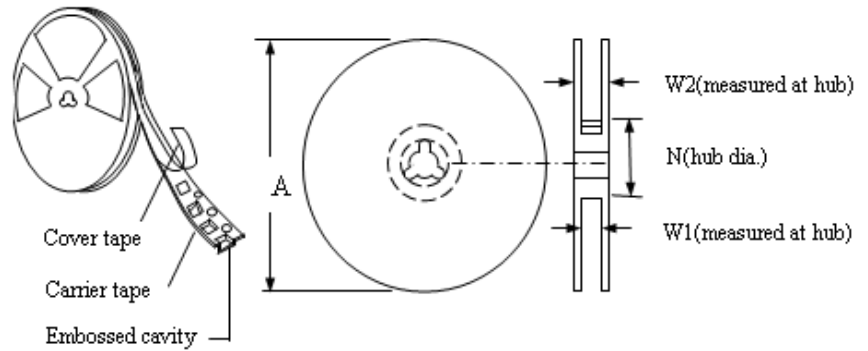

**Packaging Quantity**

Model	Quantity	Model	Quantity
DM-PSMD-005	5000	DM-PSMD-050	5000
DM-PSMD-010	5000	DM-PSMD-075	4000
DM-PSMD-020	5000	DM-PSMD-100	4000
DM-PSMD-035	5000	DM-PSMD-110	4000

**Storage**

The maximum ambient temperature shall not exceed 38°C. Storage temperatures higher than 38°C could result in the deformation of packaging materials. The maximum relative humidity recommended for storage is 60%. High humidity with high temperature can accelerate the oxidation of the solder plating on the termination and reduce the solderability of the components. Sealed plastic bags with desiccant shall be used to reduce the oxidation of the termination and shall only be opened prior to use. The products shall not be stored in areas where harmful gases containing sulfur or chlorine are present

**WARNING**

- Please read this specification before using the product.
- Use PPTC beyond the maximum ratings or improper use may result in device damage, electrical arcing and flame.
- PPTC are intended for protection against occasional over current or over temperature fault conditions and should not be used when repeated fault conditions or prolonged trip events are anticipated.
- Device performance can be impacted negatively if devices are handled in a manner inconsistent with recommended electronic, thermal, and mechanical procedures for electronic components.
- Use PPTC with a large inductance in circuit will generate a circuit voltage above the rated voltage of the PPTC.
- Avoid impact PPTC device its thermal expansion like placed under pressure or installed in limited space.
- Contamination of the PPTC material with certain silicon based oils or some aggressive solvents can adversely impact the performance of the devices. PPTC can be cleaned by standard methods.
- Requests that customers comply with our recommended solder pad layouts and recommended reflow profile. Improper board layouts or reflow profile could negatively impact solderability performance of our devices.

Notes:

The specification is intended to present application product and technical data to assist the user in selecting PPTC circuit production devices, However, users should independently evaluate and test the suitability of each product. Jinrui makes on warranties as to the accuracy or completeness of the information and disclaims any liability resulting from its use, Jinrui's only obligations are those in the Jinrui Standard Terms and Conditions of Sale and in no case will Jinrui be liable for any incidental, indirect, or consequential damages arising from the sale, resale, or misuse of its products. Jinrui reserves the right to change or update any information contained in this specification without notice.